



48V50Ah Product Manual



Please read this manual carefully before use.
Please keep it properly for future reference.

Summary

This manual is used to introduce the 48V50Ah lithium iron phosphate pack ("Product"). Please read this manual and use the product according to the relevant instructions. If you have any questions, please contact the supplier. The content includes product introduction, component introduction, installation, commissioning, system maintenance and other aspects.

The pictures in this document are for reference only, and the specific structure is subject to the physical object.



Readers

This document is mainly applicable to the following engineers:

- Sales engineer
- Technical support engineer
- Service engineer

Symbolic convention

The following signs may appear in this article, and they represent the following meanings

Symbol	Explanation
	Danger: used to warn of emergency dangerous situations, if not avoided, will lead to death or serious personal injury. Warning: used to warn of potential dangerous situations that may lead to death or serious personal injury. Note: Used to alert potentially dangerous situations that, if not avoided, may cause moderate or minor personal injury.
	For transmitting device or environmental safety warning information. If not avoided, it may lead to equipment damage, data loss, and equipment performance degradation, or other unpredictable results. The "Notice" does not involve personal injury.
	Explanation: Supplementary description of the key information of the text

Note:

- 1) please read this manual carefully before installation and use;
- 2) this product is suitable for use with -48 V communication power supply system;
- 3) the battery capacity of this product is about 60% when it leaves the factory, it is recommended to charge first;
- 4) this product should be stored for more than 6 months, should be charged at least once, each charge SOC should not be less than 90%;
- 5) this product should trigger the low-voltage protection should be charged within 12 hours;
- 6) this product rated voltage is 51.2 V, please pay attention to personal safety;
- 7) if abnormal, please contact the supplier in a timely manner.

1. Introduction

1.1 System profile

This product is an advanced product developed to meet the requirements of the new backup power supply of the current communication operators under the new trend of communication, with the characteristics of integration, miniaturization, lightness, intelligentization, standardization and environmental protection, it can be widely used in outdoor tower lamp-post station, indoor distributed weak electric well, micro-station and other environmental bad scenes, backup power supply for communication equipment such as RRU and AAU at the end of communication network. The utility model can meet the application scenarios of wall hanging, holding pole, angle steel tower and so on, and support the installation modes of flag installation, paperback installation, landing, etc.

Products in the sun, rain, dripping, wind, freezing, dust, wet outdoor environment, can be normal operation.

1.2 System characteristics

- 1) The electric battery cell adopts the controllable double-valve structure design safety valve, the safety is high.
- 2) Integrated Design: 16 Series Battery Modules + BMS + aluminum die-casting enclosure.
- 3) High energy density, stable discharge platform, long service life, greatly reduce base station rejection rate.
- 4) The Modular design can be connected in parallel to expand the capacity according to the actual need.
- 5) All-round warning and protection functions (overcharge, overdischarge, short circuit, overload, overcurrent, high temperature, low temperature, equilibrium, dormancy).
- 6) Intelligent design, with remote sensing, remote signal functions, through the dynamic monitoring system remote communication.
- 7) The panel at the bottom of the box body is convenient and suitable for quick operation and outdoor wiring maintenance.

2. Product composition and appearance structure

2.1 Product structure and size

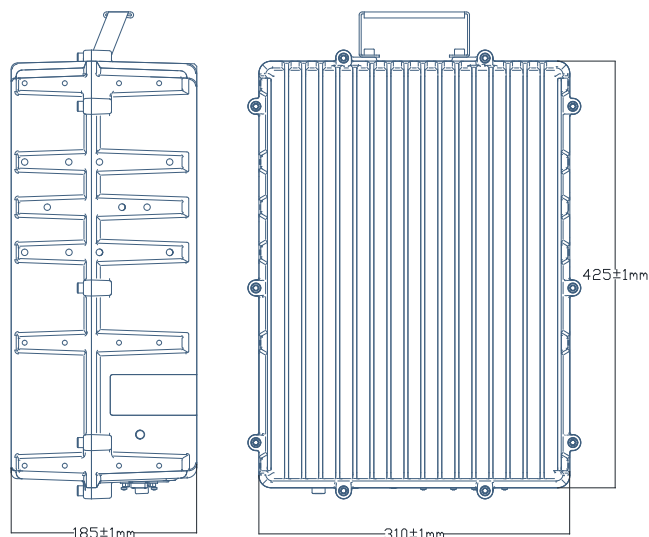

2.2 Typical product configuration table

Product name	Integrated power supply
Product model	48V50Ah
System specifications	DC48V/50Ah
Configuration	2 waterproof communication interface (DB9 base), 2 waterproof charge and discharge and expansion interface, A pressure relief valve, a battery switch
Installation method	Wall hanging flat (flag), holding pole flat (flag)
Levels of protection	IP65



Note: The actual configuration shall be based on the actual goods

2.3 Description of the product configuration

2.3.1 System configuration diagram



Note: The actual configuration shall be based on the actual goods

2.3.2 Panel interface description

Order number	Interface	Characteristic	Interface specification
①	Atmospheric valve		
②	Communication interface 2 (DB 9 master hub)	RS 485-2	Connect the communication line
③	Communication interface 1 (DB 9 hub)	RS 4851	Connect the communication line
④	Battery charge and discharge interface and capacity expansion interface	LOAD 2	"Sign L to positive", "sign N to negative"

⑤	Battery charge and discharge interface and capacity expansion interface	LOAD 1	"Sign L to positive", "sign N to negative"
⑥	Battery switch		Open the cover, press the switch for 6 seconds;
⑦	Pilot lamp		Normal green, alarm and protection are red

 Note: The actual product interface configuration shall be subject to the physical object.

Definition of communication interface socket:

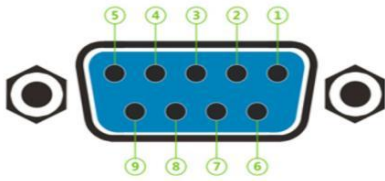

No.	Definition
1	CAN_ H
2	CAN_ L
6	ALM_IN +
7	ALM_IN -
8	RS485_ B
9	RS485_ A

LED indicator description

Battery status		Indicator status
Dormancy / shutdown	---	off
Standby	normal	Green light on 0.25S, off 3.75S
	alarm	Red light on 0.5S, off 1.5S
	protection	Red light on 0.5S, off 0.5S
Charge	normal	Green light 0.5S, off 0.5S
	alarm	Red light on 0.5S, off 1.5S
	protection	Red light on 0.5S, off 0.5S
Discharge	normal	Green light is always bright
	alarm	Red light on 0.5S, off 1.5S
	protection	Red light on 0.5S, off 0.5S
Fault		Red light is often bright

3. Product installation



- 1) The installation, commissioning and maintenance of products are performed by professionally trained personnel. Before installation and use, please read and understand the product safety precautions and operating procedures. The installation process should strictly comply with the relevant safety regulations, to avoid illegal operation resulting in personal injury, or product damage.
- 2) Please check whether the switching power supply is well-adapted.
- 3) Please check again whether the switching power supply system and this product are in the shutdown state.
- 4) Please check whether the cable connection with the corresponding level of insulation protection, strictly prevent the occurrence of metal wire exposure;
- 5) When installed, ensure the product is reliably grounded to the switching power supply system.
- 6) Use appropriate insulation tools to prevent accidental electric shock or short circuit.
- 7) If you do not have an insulating tool, you can use insulating tape to cover the entire exposed metal surface of the existing tool in addition to the end of the operation.

3.1 Installation specification

- 1) The construction site shall have at least two people or more operations.
- 2) Check whether the outer packing box of the product is damaged and whether the product specifications and models are accurate first.
- 3) After unpacking the box, check whether the materials are complete and intact according to the packing list.
- 4) The product should be removed lightly, to avoid collision, scraping, breakage and other damage phenomena and affect the use.
- 5) The metal installation tools must be insulated before use to prevent the short circuit of the battery due to unexpected conditions such as tool drop during operation
- 6) Before installation, check the wiring row and junction row to be clean.
- 7) Before installation, check that the diameter of the used can meet the maximum current requirements of the equipment operation.
- 8) The wiring layout is reasonable and orderly, and take moisture-proof and corrosion prevention measures.
- 9) Ensure that the wiring is correct, and the grounding wire should be reliably grounded.
- 10) After installation, the wiring fixing and product fixing bolts shall be checked one by one.
- 11) When the power supply is not connected after installation, the power switch of the product shall be closed.
- 12) Before the official opening, the product should be replenished to avoid damage to the product caused by excessive discharge.

3.2 Construction tools



 Note: The above tools are necessary and shall not be less than the above configuration tools.

3.3 Installation method

3.3.1 Wall-mounted flat (flag) installation

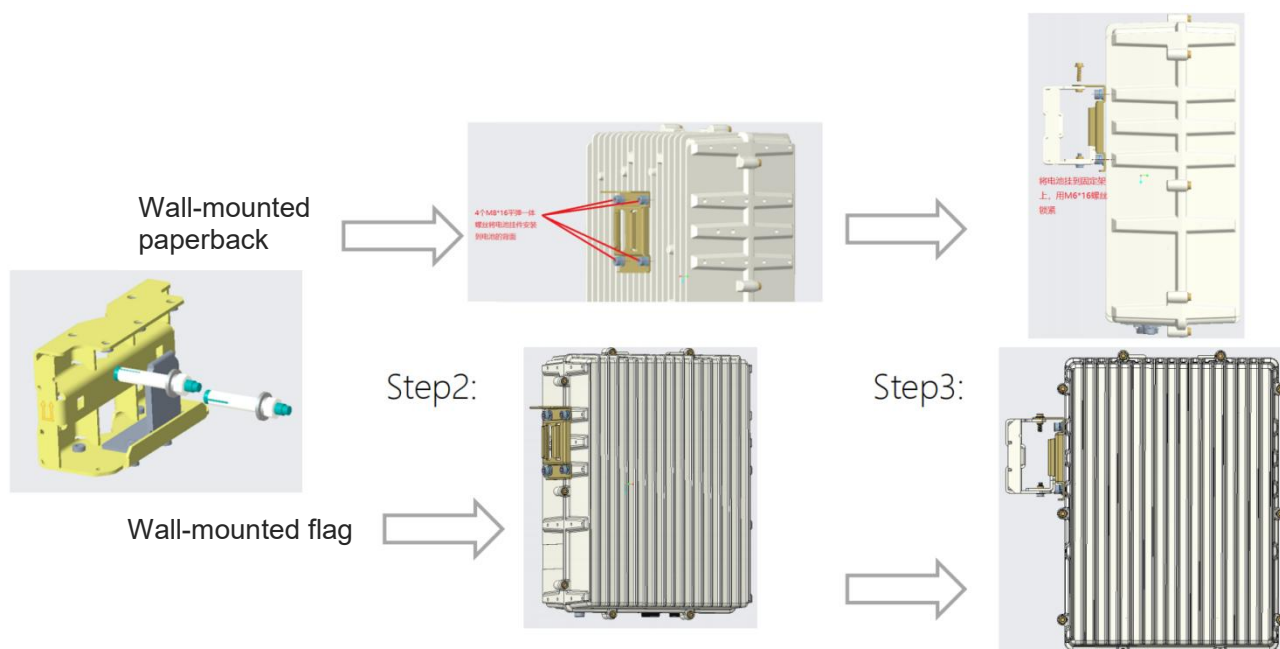

Step 1: Use two M10*80 expansion screws to fix the holding rod support to the wall;

Step 2: The power supply with four M8*16 cylinder hexagon screws fixed on the movable installation plate;

Step 3: Grasp the handle and the bracelet at the bottom and insert the transfer connector of the module into the corresponding position of the engineering installation part. At the top position, use the inner hexagonal M6*16 Combination screws connect and secure both.

3.3.2 Pole flat (flag) installation

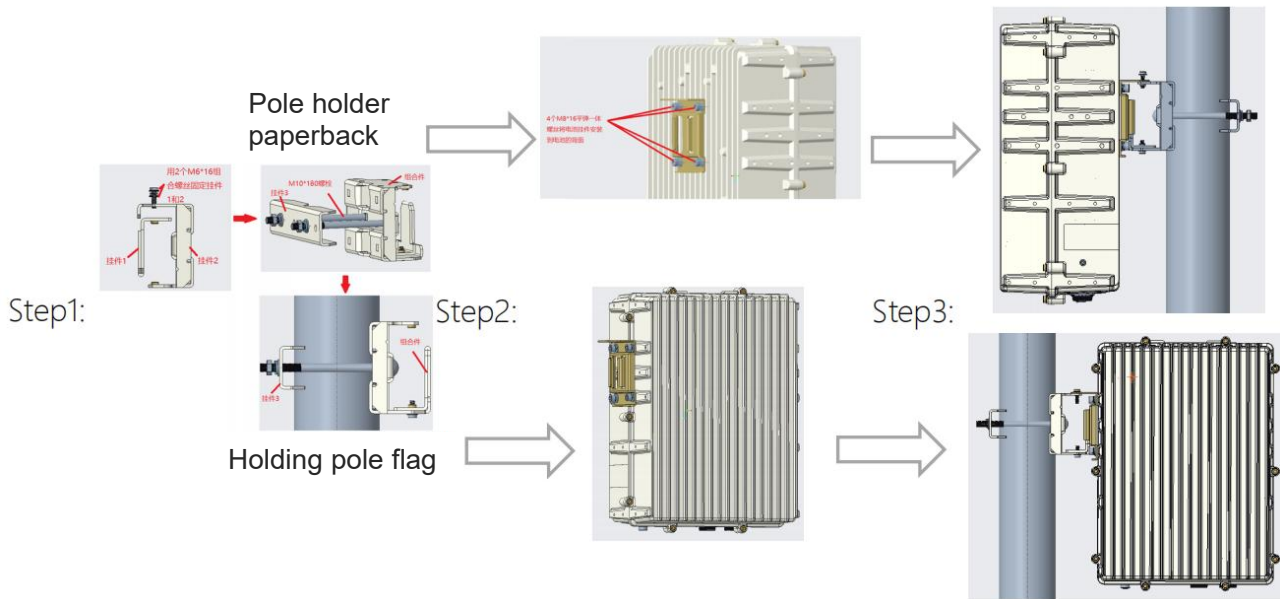

Step1: Remove wall pendants 1 and 2 and hold them together with two M6*16 combination screws.

Assembly and pendant 3 are fastened to the round rod with two M10*180 bolts.

Step 2: Fixed the power supply to the movable mounting plate with four M8*16 cylindrical hexagonal combination screws.

Step 3: Hoist the mounted battery to the assembly and tighten with M6*16 screws.

⚠ Safe:

The installation location of the equipment strictly follows the design drawings, meets the requirements of the installation space, and reserves the maintenance space.

Install fasteners to install firmly, the installation of good fixed, no distortion phenomenon.

When installed on the wall, the hole position of the module is aligned with the hole position of the expansion bolt, and the mounting piece adheres to the wall and is firmly installed.

When installed on the wall, according to the firm, not shaking hand. All cables must be inserted reliably and bolts must be locked.

If the wiring port is not connected or not in use, lock the wiring cover tightly.

3.4 Connect between the product and the power supply

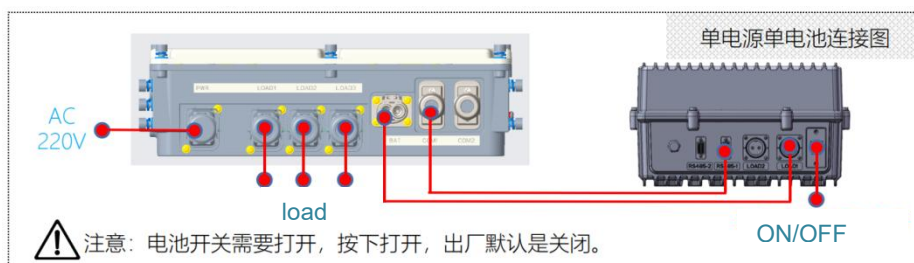

Single power supply and single battery connection diagram

⚠ Note: The battery switch needs to be turned on, pressed to open, the factory default is off.

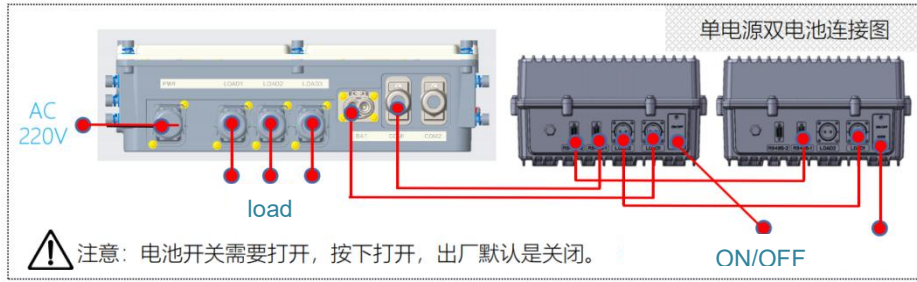

Single power supply and double battery connection diagram

⚠️Note: The battery switch needs to be turned on, pressed to open, the factory default is off.

3.4.1 Connection of battery power lines

- 1) Remove the waterproof connection plug from the spare attachment and remove the connection plug. The external dimensions and disassembly diagram of the connecting plug are as follows:

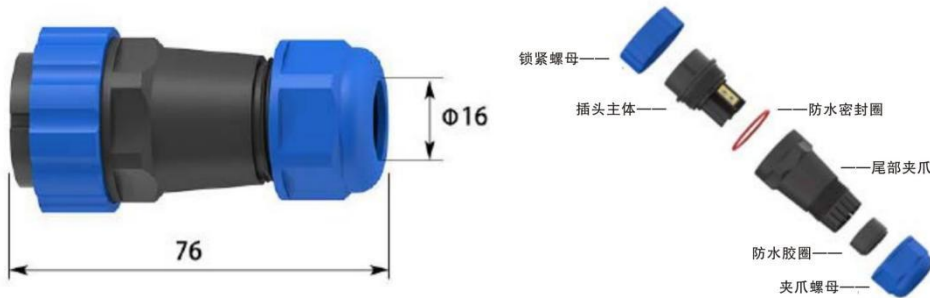

- 2) Peel the power line-the length is about 14mm, and then pass the power line through the clip claw nut, waterproof rubber ring, and the tail clip claw, as shown in the figure below:



- 3) After putting the lock nut and waterproof sealing ring on the main body of the plug, put the positive pole line into the L (positive pole) of the main body of the plug, and use the inner hexagon wrench fastening. Pass the negative pole line into the N (negative pole) of the main body of the plug, and secure it with the accessory hexagonal socket wrench, as shown below:



- 4) Then tighten the plug body and the tail clamp, the lock nut and the clamp respectively.

- 5) Finally, insert the made cable into the charge and discharge interface of the battery box, and tighten the lock nut.

3.4.2 Connection of battery communication cable

- 1) Remove the waterproof DB9 communication wiring harness from the spare accessories.
- 2) As shown in the figure below: push the DB terminal of the signal connector plug into the waterproof case.

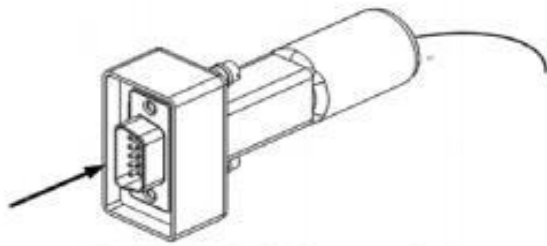

Push the DB terminal into the waterproof case.



Waterproof DB9 communication harness

- 3) Plug the signal connector into the signal socket of the module and lock it with a screwdriver.

3.4.3 Connection of the ground wire

- 1) Prepare cables (select suitable yellow-green cables) and OT terminals, thermoplastic casing, hydraulic pliers, hot air gun, and make protective ground wire cables.

Make the cable map of the protection ground

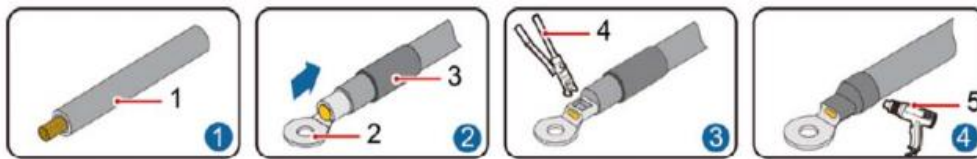

1. Cable 2. OT terminal 3. Thermoplastic sleeve 4. Hydraulic clamp 5. Hot air gun

- 2) Attach the protective ground wire on the ground wire interface of the battery box with a cross screwdriver and tighten it.

3.5 Check after installation

3.5.1 Hardware installation check

- 1) Confirm that all the screws are tightened (especially for the electrical connection part). Flat pad, elastic pad should be complete, and can not be installed in reverse.
- 2) Check whether the air plug is completely inserted into the socket, and locked firmly.

3.5.2 Electrical connection inspection

- 1) Whether the cables in each plug are locked, have good contact and no loosening phenomenon.
- 2) Check whether the positive and negative electrodes of the battery and the battery line are connected correctly to ensure that there is no short circuit.
- 3) Check whether the input and output power cord and protective ground wire are correctly connected, and ensure that the input and output have no short circuit through measurement.

3.5.3 Cable installation inspection

- 1) Check whether all cables are connected and reliable.
- 2) Check whether all cables are straightened and tied to the nearest cable buckle without distortion or excessive bending.
3. Check whether the label of the cable is correct to ensure that it does not fall or break, and the label is in the same direction for easy viewing.

4. Product use

4.1 Product use steps

- 1) After the installation of the product, the waterproof charge and discharge interface will be correctly connected to charge or open the tap switch, and the product will enter the standby working state.
- 2) When the communication switch power supply is loaded, the product enters the charging state; when the product is fully charged, the product goes to standby operation.
- 3) When the municipal power is cut off, the product enters the discharge working state without delay and provides backup power support to the communication equipment; in the process, the power of the product returns to the discharge state and automatically switches to the dormant working state.

4.2 Product dormancy and wake-up function

The product has the hibernation function, and the BMS power consumption is reduced to μ A level, which can minimize the power consumption of BMS on the battery pack.

- 1) Standby hibernation (while meeting the conditions: ① no communication ② single section voltage is less than 3.3V ③ no charge / discharge current).
- 2) Undervoltage dormancy (① undervoltage protection ② delay of 30 minutes).
- 3) Manual dormancy.

The product has the dormant wake up function, and the wake up conditions are as follows:

- 1) Charge and wake up.
- 2) Press the reset button to wake you up to start the boot.

4.3 Communication function

4.3.1 CAN communication processing

After all batteries are powered on, obtain the host and the address of the machine in the order of power. If charged at the same time, the primary address will be obtained in the sequence of battery serial number. After the host communication is disconnected, the host and slave address can be retrieved automatically without restart or power loss. Host address is 1, and slave address

In the order, from 2 to N. The host engine is responsible for coordinating the charge and discharge and capacity balance between multiple batteries.

4.3.2 RS485 communication processing

When the battery communicates with the power supply for RS 485, return the data to the power supply according to the different device address commands. The battery can be powered through the RS 485. Read the multiple battery pack information and history.

4.3.3 Communication interface

The battery pack distributes addresses through CAN bus parallel communication, RS 485 interface realizes communication with power supply, and multi-machine parallel bus interface is shown in the following figure. Parallel communication supports 16 groups.

4.4 Security protection and alarm function

1) High charging total pressure protection and recovery function

The battery pack has the function of total voltage protection and recovery. When the total voltage reaches the alarm set time and the delay time of the overvoltage alarm, the BMS considers that the charging overvoltage alarm state occurs, but does not affect the normal charging function; when the total voltage rises to the total pressure protection setting time and the delay time of the overvoltage protection detection, the BMS considers that the charging overvoltage state occurs, cut off the charging loop and alarm to ensure the safety performance of the battery pack, but does not affect the normal discharge function. When the total voltage decreases to the recovery set value, the battery pack returns to normal charging operation. This function can be set off and enabled through the upper computer software.

2) Total discharge pressure is too low for protection and recovery function

The battery pack has low discharge voltage protection and recovery function, When the total voltage reaches the total voltage alarm set point and the duration exceeds the delay time of undervoltage alarm, BMS considers the discharge too low alarm state and alarm, But it does not affect the normal discharge function; When the total voltage drops to the total voltage protection setting value and the duration exceeds the undervoltage protection detection delay time, BMS considers that the total discharge voltage is too low, Cut off the discharge circuit and give an alarm, Ensure the safety performance of the battery pack, However, it does not affect the normal charging function; the BMS becomes dormant, When the switching power supply resumes the charge, When the total voltage rises to the recovery set point, BMS considers that the battery pack discharge too low protection state has been removed, The battery pack returns to normal operation condition. This function can be set off and enabled through the upper computer software.

3) High single battery voltage protection and recovery function

The battery pack has a high battery voltage protection and recovery function, When the single voltage reaches the high voltage alarm set point and the duration exceeds the voltage alarm detection delay time, BMS considers that the single voltage is too high and the alarm state occurs and the alarm, However, it does not affect the normal charging function; when the single voltage rises to the single voltage is too high protection set point and the duration exceeds the overvoltage protection detection delay time, BMS considers that the single charging voltage occurs, Cut off the charging circuit and give an alarm, Ensure the safety performance of the battery pack, However, it does not affect the normal discharge function; when the monomer voltage is reduced to the recovery set value, BMS considers that the single voltage charging has been removed, The battery pack returns to normal operation condition.

4) Single battery voltage is too low for protection and recovery function

The battery pack has the single battery voltage is too low protection and recovery function, When the single voltage reaches the voltage alarm set point of too low and the duration exceeds the detection delay time of the undervoltage alarm, BMS considers that the single voltage is too low to alarm state and alarm, However, it does not affect the normal discharge function; when the unit voltage drops to the low protection setting value of the unit voltage and the duration exceeds the delay time of undervoltage

protection detection, BMS considers that the monomer discharge voltage is too low, Cut off the discharge circuit and give an alarm, Ensure the safety performance of the battery pack, But it does not affect the normal charging function; The BMS enters a dormant state, When the switching power supply resumes the charge, When the monomer voltage rises to the recovery set point, BMS considers that the low voltage discharge has been removed, The battery pack returns to normal operation condition.

5) Short circuit protection

The battery pack has the short circuit protection function. After the short circuit at the output end of the battery pack, when the discharge current exceeds the short circuit protection current (greater than 3C) and the duration exceeds the delay time of the short circuit detection, the short circuit occurs, and the circuit is cut off and alarms; the battery safety will not affect other equipment at the station; After the external short circuit is cancelled, the battery pack will automatically return to normal working state (it can be manually reset to normal operation).

6) Discharge and overcurrent (load) protection and recovery function

The battery pack has the function of discharge over current (load) protection and recovery function. When the discharge current exceeds the overcurrent (load) alarm set point and the duration exceeds the delay time of discharge over current alarm detection, BMS considers that the discharge over current alarm state occurs and alarms, but it does not affect the normal discharge function. When the discharge current exceeds the overcurrent (load) protection set value and the duration exceeds the discharge overcurrent detection delay time, BMS considers that the discharge overcurrent protection state occurs, and the discharge circuit is cut off and alarms the safety performance of the battery pack; after the overload cancellation or the discharge current drops to the set value, the battery pack returns to the normal discharge state. This function can be set off and enabled through the upper computer software.

7) Charging and overcurrent protection

The battery pack has the function of charging overcurrent protection. When the charging current reaches the charging current overcurrent alarm setting value and the duration exceeds the delay time of charging overcurrent alarm detection, BMS considers that the charging overcurrent alarm state occurs and alarm, but it does not affect the normal charging function. When the charging current reaches the charge overcurrent protection setting and the duration exceeds the delay time of charge overcurrent detection, BMS considers that the charge overcurrent protection state occurs, cut off the charging circuit and alarm the safety performance of the battery pack; When the charging current drops to the charge overcurrent protection recovery value, BMS considers that the charge overcurrent protection state has been lifted and the battery pack returns to the normal charging condition. This function can be set off and enabled through the upper computer software.

8) Overtemperature protection and recovery function

The battery pack has the function of charge and discharge over temperature protection and recovery. When the temperature reaches the over temperature alarm set value and the duration exceeds the over temperature alarm detection delay time, BMS considers that the over temperature alarm state occurs, but it does not affect the normal charge and discharge function. When the temperature reaches the set value of overtemperature protection and exceeds the delay time of overtemperature protection detection, BMS considers that the overtemperature protection state occurs, cut off the circuit and alarm to ensure the safety performance of the battery pack; When the temperature drops to the overtemperature protection

recovery value, BMS considers that the overtemperature protection state has been removed, and the battery pack returns to normal charge and discharge operation.

9) Low-temperature protection and recovery function

The battery pack has the function of charge and discharging low temperature protection and recovery. When the temperature reaches the low temperature alarm set value and the duration exceeds the low temperature alarm detection delay time, BMS thinks that the low temperature alarm state occurs, but it does not affect the normal charge and discharge function. When the temperature reaches the set value of low temperature protection and exceeds the delay time, BMS considers that the low temperature protection state occurs, the circuit is cut off and the safety performance of the battery pack; when the temperature rises to the low temperature protection recovery value, BMS considers that the low temperature protection state has been lifted and the battery pack is restored to normal charge and discharge operation.

5. Maintenance

5.1 Handling and placement

- 1) Must be operated by qualified and authorized personnel.
- 2) Due to the heavy weight of the battery system, please handle it carefully.

5.2 Common faults and solutions

Order number	Fault phenomenon	Analysis of causes	Terms of settlement
1	No DC output after startup	Low battery voltage, over-discharge protection	Charging
2	Low power	The charging voltage is too low	Adjust the equalizing and floating charging voltage of switching power supply to the required parameters Requires parameters
3	Short power supply time	The battery pack is not fully charged	Check the charging voltage, charging current and other parameters of switching power supply
4	Communication failure	Communication line or address problem	Check ports and lines

5.3 Routine maintenance

 Danger: Maintenance of batteries must be done by qualified and authorized personnel.

 Danger: Some maintenance items must close the system at the beginning.

Voltage check: check the voltage of the battery system through the monitoring system. Check whether the system has abnormal voltage. For example, the voltage of a single battery is abnormally high or low.

SOC check: check the SOC of the battery system through the monitoring system, and check whether the SOC of the battery system is normal.

Cable inspection: Visually inspect all cables of the battery system. Check whether the cable is broken, aged and loose.

Historical inspection: analyze whether there are accidents (alarm and protection) in the historical records, and analyze the causes.

6. Product parameter index

6.1 Basic parameters

Model specification	48V50Ah
Battery type	lithium iron phosphate
Nominal voltage	51.2V
Nominal capacity	50Ah
Cell specifications	3.2V /50Ah
Battery pack mode	16 single cells + BMS + aluminum outer case
Battery pack size	W 310×D 185×H 425±1mm
Weight	31±1.0 kg
Working temperature	-20~60℃
Storage temperature	0~40℃
Working relative humidity	≤90% (40℃±2℃)
Work altitude	0 ~ 3600m
Working atmospheric pressure	70kpa-106kpa
Noise	0 db
Cycle life	3600 Times

6.2 Charging technology and operation parameters

Charging mode	CC/CV
Generalized total voltage	56.8V
Floating charge total voltage	54.4V
Charging current	5A~25A
Charge current-limiting current value	10A
Single-cell overvoltage alarm	3.56V
Single-cell overvoltage alarm delay time	2000mS
Single-cell overvoltage protection	3.60V
Single-cell overvoltage protection delay time	2000mS
Total voltage overvoltage alarm	57.0V
Delay time of the total pressure overvoltage alarm	1000mS

Total voltage and overvoltage protection	58.0V
Total voltage and overvoltage protection delay time	2000mS
Charge excessive alarm	$\geq 23A$
Charge overcurrent alarm delay time	1000mS
Charging over-current protection	$\geq 25A$
Charge overcurrent protection delay time	15000mS
Charging high temperature alarm	40℃
Charging low temperature alarm	2℃
Charging high temperature protection	60℃
Charging low temperature protection	0℃

6.3 Discharge technology and operation parameters

Discharge current	0A~50A
Single-cell overdischarge alarm	2.90V
Single-cell overdischarge alarm delay time	2000mS
Single-cell overdischarge protection	2.70V
Delay time of single-cell overdischarge protection	2000mS
Total voltage overdischarge alarm	49.0V
Total voltage alarm delay time	1000mS
Total voltage release protection	40.0V
Total voltage release protection delay time	2000mS
Discharge overcurrent alarm	$\geq 55A$
Overdischarge alarm delay time	1000mS
Discharge and overcurrent protection	$\geq 65A$
Drain overcurrent protection delay time	15000mS
Discharge high-temperature alarm	40℃
Discharge low-temperature alarm	-10℃
Discharge high-temperature protection	60℃
Discharge low-temperature protection	-20℃

6.4 Other techniques and surgical parameters

Equalize the turn-on voltage	3.50V
Equalize the open voltage difference	20mV
Equalizing current	75mA
Short circuit protection current	$> 3C$
Short circuit protection delay	$\leq 900\mu s$

Short circuit protection recovery mode	The load is disconnected, and it is restored automatically (or manually reset)
BMS working current	$\leq 30\text{mA}$
BMS dormancy current	$\leq 100\ \mu\text{A}$
Storage capacity	> 500 Articles
Voltage display accuracy	$\pm 10\text{mV}$
Current display accuracy	1.2%
SOC display precision	2.5%
Temperature display accuracy	1°C

7. Packing list

Order number	Description	Quantity
1	Integrated battery system	1 unit
2	Product manual	1 pc
3	Certificate of quality	1 pc
4	Two-core waterproof plug	2 units
5	Waterproof DB9 communication harness	1 pc
6	Installation accessories	1 unit